

QUANTUM ACCESS HATCH

ECO

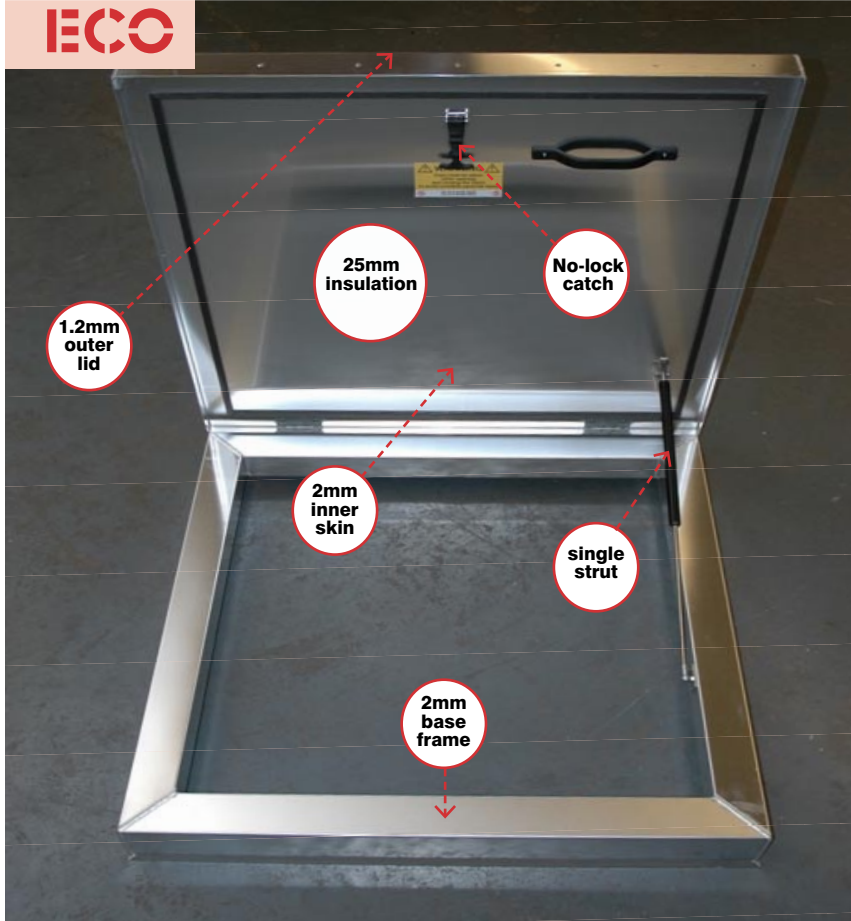

Quantum ECO is a budget, low profile access hatch designed for mounting onto all types of roof. For aluminium and steel standing-seam roofs, a separate kerb upstand, is available.

Quantum ECO is manufactured from 100% recyclable aluminium and carries a full manufacturer's warranty.

PRODUCT INFORMATION

M.R. SITE SERVICES

The innovative design of Quantum Eco Access Hatch provides a product range which meets the demands of specifiers and installers.

Construction

- Fully welded 1.2mm stucco embossed aluminium outer lid with 2mm aluminium inner skin. 2mm base frame.

Finish

- Can also be supplied either mill-finished, powder coated to match BS/RAL specifications or painted using the PPG Duranar ADS paint system which meets or exceeds the durability and colour retention criteria of AAMA no 2605.

Fixing

- Dependant on roof type, either fixed to a previously installed kerb upstand, welded aluminium soaker with fully insulated 150mm minimum aluminium upstand, or via Roll-A-Flex into a steel roof or similar.

Mechanism

- Specially designed heavy-duty hinges.
- Gas assisted strut for ease of opening and closing.

Security

- Inner latch mechanism (not lockable as standard) for access from the inside.

Weather sealing

- All Quantum Access hatches are fitted with rubber inner seals for weather and draught proofing.

Insulation

- 25mm thick rigid insulation is sandwiched between the outer lid and inner skin to provide thermal insulation against condensation and heat loss.

Durability

- Strong and lightweight.
- Corrosion-free.

Dimensions

- Standard sizes: 750 x 750mm; 900 x 900mm; 1000 x 1000mm

Weight

- Approximately 30kg per square meter.

Maintenance

- Should be inspected annually. See maintenance schedule.

Sales and after-sales support

- CAD (.dwg) files for direct import into your drawings can be provided.
- Call the sales office for more details.

M.R. Site Services Ltd

Unit 6 Worcester Trading Estate Blackpole Worcester WR3 8HR England
 t: +44(0)1905 755055 f: +44 (0)1905 755053 e: welding@mrsiteservices.co.uk
www.mrsiteservices.co.uk

QUANTUM ACCESS HATCH

PRODUCT INFORMATION

M.R. SITE SERVICES

IECO

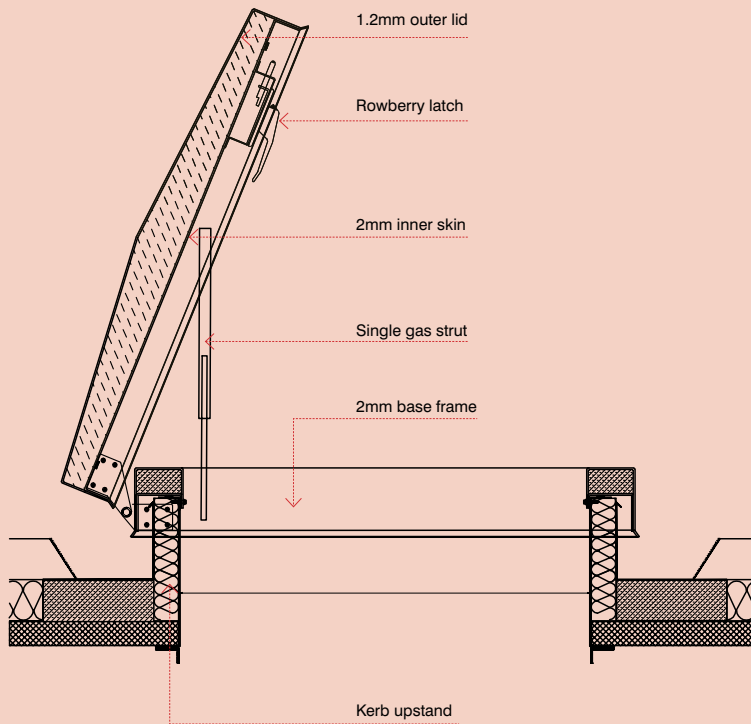

Quantum Access Hatches

The Quantum Eco Access Hatch provides a quick, easy and safe method for the inspection, and routine maintenance, of all roof mounted equipment, machinery and services.

M.R. Site Services Ltd

Unit 6 Worcester Trading Estate Blackpole Worcester WR3 8HR England

t: +44(0)1905 755055 f: +44 (0)1905 755053 e: welding@mrsiteservices.co.uk

www.mrsiteservices.co.uk

QUANTUM ACCESS HATCH

PRODUCT INFORMATION

M.R. SITE SERVICES

LOCKS AND CATCHES

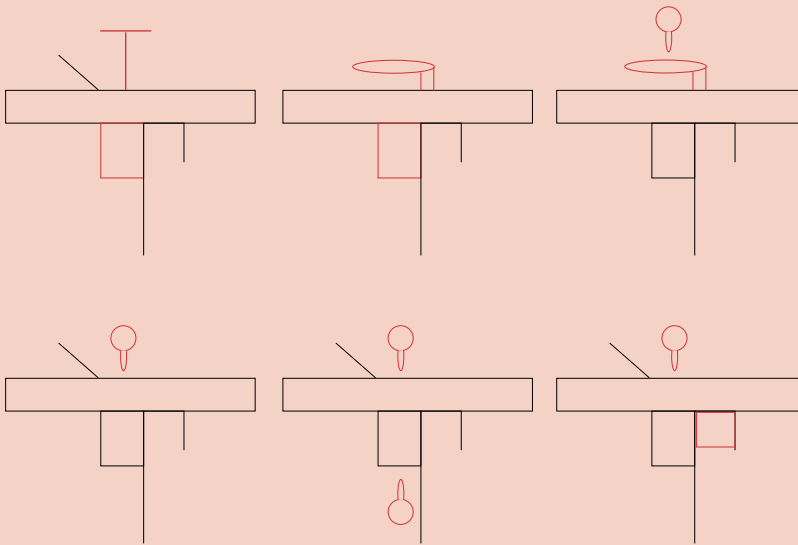

Quantum Access Hatch security

A wide range of locks and catches is available for Quantum Access Hatches, depending on model.

Standard cablock

Allows opening from inside only.

Standard cablock with internal hasp and staple

Allows opening from inside only, but with a higher degree of security

Standard cablock and tee key

Allows opening from inside and outside.

Standard cablock and non-locking external handle

Allows opening from inside and outside.

Standard cablock and external handle

Allows opening from inside and outside. Opening from inside is only possible once the external handle is unlocked.

European deadlock

Allows opening from inside with a thumb turn catch and from outside with a key.

European deadlock

Allows opening from inside and outside with one key.

Electromagnetic locking

For use in conjunction with push button, fire alarms and key switches.

M.R. Site Services Ltd

Unit 6 Worcester Trading Estate Blackpole Worcester WR3 8HR England

t: +44(0)1905 755055 f: +44 (0)1905 755053 e: welding@mrsiteservices.co.uk

www.mrsiteservices.co.uk



QUANTUM ACCESS HATCH

PRODUCT INFORMATION

M.R. SITE SERVICES

ASSOCIATED PRODUCTS

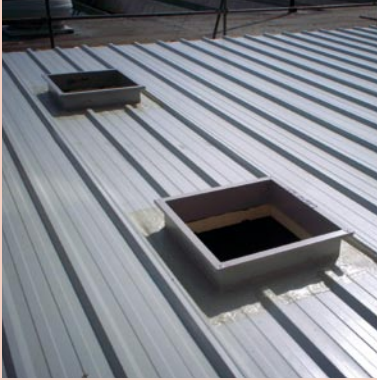

Roll-a-Flex

Roll-a-Flex is a proven, fully reinforced, liquid waterproofing system for use on any roofing material, profile or surface finish, or where welded joints are impractical.

Roll-a-Flex offers first-class fire-resistance, can be coloured to match existing materials and is guaranteed for 10 years. Contact the sales office for further information.



Safety rails

Certain locations and situations demand extra protection around access hatches, particularly in areas where high winds or icy conditions prevail.

The Quantum product range includes a family of tubular or square section handrails, manufactured to BS 5395-3: 1985.

M.R. Site Services Ltd

Unit 6 Worcester Trading Estate Blackpole Worcester WR3 8HR England
t: +44(0)1905 755055 **f:** +44 (0)1905 755053 **e:** welding@mrsiteservices.co.uk
www.mrsiteservices.co.uk

QUANTUM ACCESS HATCH

PRODUCT INFORMATION

M.R. SITE SERVICES

MAINTENANCE SCHEDULE

Access onto Roof

- All maintenance personnel must use approved access equipment and safety harnesses where appropriate at all times.

Inspection

- The access hatch should be inspected annually by suitably qualified personnel to test for accidental damage, evidence of tampering and for build up of dirt and debris.
- It may be necessary to inspect the access hatches more frequently depending on the location or environment.
- Any damage must be repaired forthwith. Loose debris such as leaves should be removed.
- Sedimentary deposits (mud, dirt, bird dropping etc) should be removed immediately otherwise permanent staining and corrosion may occur.
- Should it be necessary to remove any part of the access hatch for replacement then this should only be carried out by suitably qualified personnel. If this is necessary, suitable weatherproofing and security measures must be put in place.

Cleaning

- Where the access hatch requires cleaning then it should be washed down with fresh water using a hose and soft bristle brush.
- In areas where heavy industrial deposits dull the surface a solution of fresh water and good quality household detergent or proprietary cleaner may be applied to ensure a thorough cleaning.
- For household detergents, use a 10% solution.
- A thorough rinse with clean fresh water must follow the wash.

Caution:

- When cleaning, the following points should be noted:
- Stronger concentration of cleaners than those recommended can damage the aluminium or polycarbonate.
- Rinse thoroughly to remove all detergents after cleaning.
- Wire brushes, steel wool, abrasives or cleaning tools which abrade the aluminium surface must not be used.
- If the Access Hatch has a polycarbonate cover, do not clean with solvents or with cleaners containing high alkaline contents.

M.R. Site Services Ltd

Unit 6 Worcester Trading Estate Blackpole Worcester WR3 8HR England
t: +44(0)1905 755055 **f:** +44 (0)1905 755053 **e:** welding@mrsiteservices.co.uk
www.mrsiteservices.co.uk